

# 1

## Introduction

### ■ 1.1 The Importance of Energy Technology in Plastic Processing

The main processes for producing plastic materials and manufacturing products made of plastics are shown in Figure 1.1. Due to lower processing temperatures, they are more energy-efficient than processes for producing metal parts. However, most of them are demanding in terms of process engineering. In particular, this applies to procedures called “*Urformen*” in German, i. e., creation of the product shape (primary shaping). Due to their importance compared to the other two common types of plastics, thermosets and elastomers, the *focus is on thermoplastics* in this book.

Temperatures in thermoplastics processing usually are between room temperature and approximately 300 °C, in some exceptional cases up to 400 °C. Common standard plastics have processing temperatures in the range of 200 °C to 250 °C [WK-1]. For several reasons, thermal engineering issues play a dominant role, particularly regarding

- Economy and sustainability (energy requirements, cycle time determined by heating and cooling, future production methods, etc.)
- Product quality (strongly influenced by process control, mainly its temperature curve)

Therefore, it is appropriate to address these issues in more detail in the following chapters and provide the necessary basics for their treatment.

Energy-intensive processes such as injection molding or extruding occur in many variants. Due to the lower processing temperatures, energy requirements in the plastics sector are considerably lower compared to those for processing metals, as mentioned above. Main energy requirements are:

- Electrical or mechanical energy for drives and movement (pumps, screws, tools, presses, etc.)

- Thermal or electrical energy for heating and cooling the plastic material, and, for example, for controlling the temperature of tools or calender rollers
- Electrical energy for welding processes, e.g., laser welding

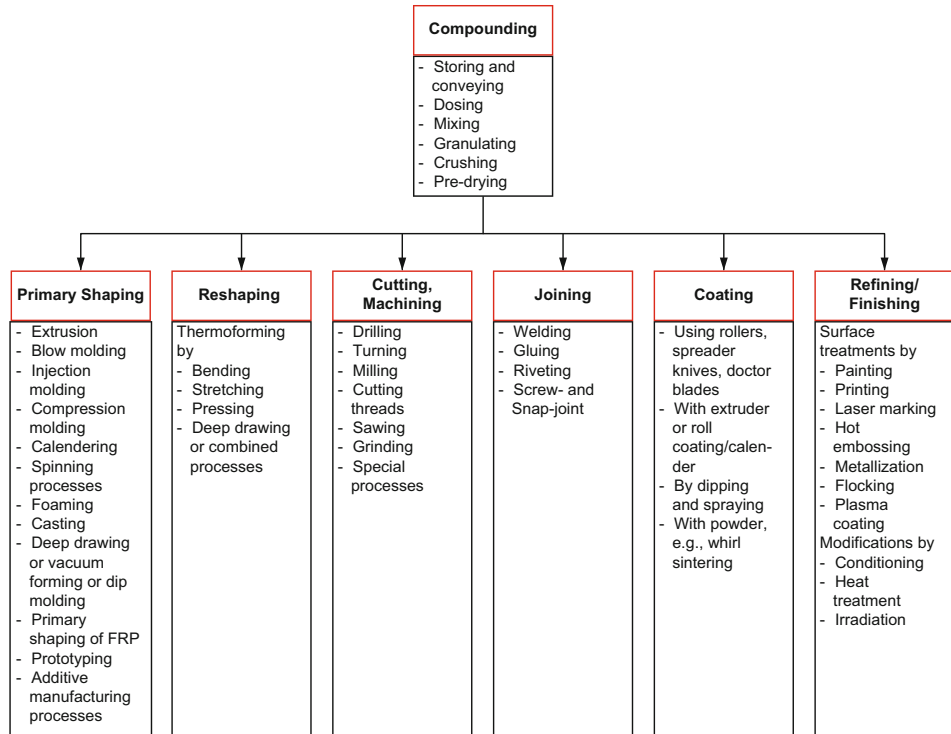

**Figure 1.1** Manufacturing processes in plastics technology, from [KA-1]

In the case of injection molding, for example, the proportion of energy costs to total manufacturing costs is only about 3% to 5% [KV-1]. This value seems to be very small. However, energy is required several times during plastic processing: heating the granulate, controlling the temperature of the tool, and driving the injection molding machine. Increasing energy efficiency and saving energy are permanent tasks.

**Use of waste heat** In modern production plants, the waste heat of manufacturing processes is used for space heating, air-conditioning, or energy storage.

**Cycle time** The cycle time has a considerable impact on the economic efficiency of injection molding processes. On the other hand, cycle time is strongly dependent on the heating and cooling times. These, in turn, depend on the intensity of the heat transfer processes.

**Quality** The quality of products made of plastics depends strongly on the temperature curve of the machinery (tools, rollers, etc.) – a matter of thermal process control – which, in turn, determines the cycle time.

These few remarks may show that

- interdisciplinary approaches are needed when dealing with energy issues.
- in general, attention should be paid to energy technology.

This is done in practice but often on an empirical basis. Only in recent years have scientific methods been applied for process optimization. Our contacts with machine manufacturers and manufacturing companies show that sustainability in general and resource efficiency in the use of energy and materials, in particular, are of great importance.

In this book, we limit ourselves to fundamentals and their applications required to assess existing systems (analysis) and identify measures for improving the energy efficiency of plastic process design. We do not address questions of machinery design, design of their components (dies, screws, molds, etc.), electrical engineering, and control technology.

The behavior of plastics in the solid and molten states is much more complex than that of metals, especially with regard to elastic, viscous, and caloric behavior. Chapters 2 and 4 deal with these topics.

## ■ 1.2 Plastic Processing Stages

Figure 1.2 shows the sequence of general plastic processing stages for thermoplastics [KV-8]. Three thermomechanical processing steps are relevant:

- *Melting stage*: The plastic, initially in a solid state, either as a powder or as a pellet, is converted to a molten state. Depending on the type of plastic, semi-crystalline or amorphous, different physical phenomena influence the energy required for the melting process.
- *Shaping stage*: A specified shape is imposed on the molten plastic by injecting or blowing it with pressure into a mold or through a die.
- *Third stage*, where the final shape of the (solid) product is achieved by drawing, stretching, or blowing and eventually by cooling.

Energy in different forms is required in all processing stages.

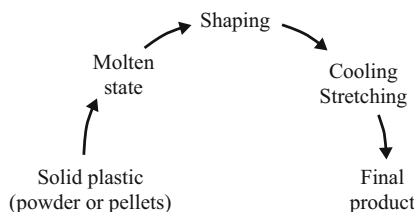

**Figure 1.2**

Plastic processing stages, from [KV-8]

## ■ 1.3 Logic for Processing Design

Plastics have specific properties that are decisive for the processing design. The following explanations are taken from [KV-8], partially from [KV-9].

### Thermally Insulating Character of Plastic Melts

The *thermal conductivity* of plastic melts is on the order of magnitude of 0.2 W/(m·K) only, which means two to three orders of magnitude lower than that of metals, leading to high cooling or heating times. According to the basics presented in Chapter 7, cooling and heating times increase with increasing wall thickness, approximately with the second power. The orders of magnitude are:

Wall thickness	Cooling or heating time
0.1 mm	0.1 s
1 mm	10 s
10 mm	1000 s

*This shows that melting a polymer by unique conduction from equipment walls would lead to unacceptable long residence times and low flow rates. That is why all melting processes require significant mechanical energy input, often much more extensive than thermal energy transferred by conduction. The low thermal conductivity also implies that the majority of plastic products are less than a few millimeters thick to minimize the cooling times and favor high production rates [KV-8].*

### Very High Viscosity of Plastic Melts

Under typical processing temperatures, molten plastics have viscosities of about  $10^3$  Pa·s, a million times higher than that of water. The practical consequences are:

- *Reynolds numbers* – representing the ratio of inertia to viscosity terms, see Chapter 4 – are extremely low. Therefore, the flows of molten plastics are never turbulent, and the inertia terms are usually negligible.
- Heating plastics in the barrel of an extruder or an injection molding machine is achieved by viscous dissipation and electric heating.
- *High pressures* are required to ensure the flow of plastic melts in dies and molds at high flow rates, typically 100 MPa or more for injection pressures, 5 to 50 MPa in extruders.

### Combined Insulating Character and High Viscosity

The combination of high viscosity, viscous dissipation, and low thermal conductivity creates large temperature gradients in plastic melt flows. Increased local temperatures can lead to the degradation of the plastic. Therefore, viscous dissipation and applied flow rates need to be limited. In some cases, the viscous dissipation dominates so that even cooling is necessary, a step to avoid plastic degradation. However, this is a step to be avoided in the interest of energy efficiency [KV-2].

*On the other hand, the high viscosity of polymers coupled with their low conductivity allows us to design processes in ambient air where extrudates remain in the molten state before going through shaping devices or drawing systems. These properties have led to the development of many downstream extrusion processes: spinning, blowing, stretching [KV-8].*

### Sensitivity of Viscosity to Shear Rates and Temperature

*Typically, the viscosity of a molten polymer may decrease by a factor of five when the shear rate is increased by a factor of ten, and it may drop by a factor of two when the temperature is increased by 20 °C [KV-8].*

The high sensitivity of viscosity to the shear rate and temperature significantly impacts flow behavior and process optimization.

### Viscoelasticity

A plastic may behave as a liquid or a solid depending on temperature and the speed at which the molecules deform. This behavior, which ranges between liquid and solid, is referred to as the viscoelastic behavior. Viscoelasticity refers to the combination of viscous and elastic material properties. *Linear viscoelasticity* is limited to plastic systems undergoing small or slow deformations, whereas *nonlinear viscoelastic models* are required for large and rapid deformations [KV-9].

In plastic processing, viscoelasticity plays many roles, such as:

- It stabilizes the drawing or biaxial stretching of plastic melts, thus allowing spinning at high strain rates, blow molding, and thermoforming with homogenized thicknesses.
- It may be the origin for the onset of instabilities in shear flows.
- It is responsible for the swelling at the outlet of dies.

In Chapter 2 we cover a few aspects of viscoelasticity. Simple linear viscoelastic models provide some basic understanding of the behavior of plastic materials during deformation.

## ■ 1.4 Required Fundamentals

### 1.4.1 Overview

Figure 1.3 provides an overview of the necessary basics of thermodynamics, fluid mechanics, heat transfer, and material behavior, especially the complex flow and stress-strain behavior of plastic melts (rheology) in plastic processing. In this book, we cover the basics of these disciplines, which we believe to be relevant in the context of plastic processing. For further details, the reader is referred to selected standard textbooks:

- Thermodynamics            In English: [TH-3 to 5]    In German: [TH-1, 2]
- Fluid mechanics            In English: [FM-2]            In German: [FM-1]
- Heat and mass transfer    In English: [WU-2, 3]    In German: [WU-1, 4, 5]

Information on material behavior, including material data, is provided in Chapter 2.

#### Fluid mechanics

- Conservation of mass, impulse, momentum
- Equilibrium conditions
- Flow behavior (rheology)
- Shear and elongational flows

#### Thermodynamics

with its 4 main laws:

- 0: Thermal equilibrium
- 1: Conservation of energy
- 2: Entropy as state property "quality of energy": exergy and anergy (energy = exergy + anergy)
- 3: Reference state of entropy = 0

#### Heat transfer

- by
- Heat conduction
  - Convection: forced and free convection
  - Radiation
  - Their combinations

#### Behavior of materials

- Thermal & caloric equations of state
- For dealing with thermal process engineering; relevant material data for gases, liquids (in particular: coolants), thermoplastics, cross-linked elastomers, thermosets

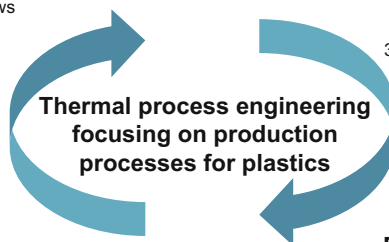

**Figure 1.3** Interaction of the disciplines thermodynamics, fluid mechanics, heat transfer, and material behavior required in thermal process engineering

Besides heat transfer, mass transfer is required for treating processes such as mixing, degassing, and pre-drying. To limit the volume of this book, we do not cover the fundamentals of mass transfer. Instead, we refer to the standard textbooks mentioned above. Similarly, in Chapter 8, which provides an overview of drying

processes, we only deal with the basics necessary for treating simple drying processes under ambient air conditions.

The abovementioned basic disciplines are treated individually with partial overlaps in standard textbooks. Figure 1.3 illustrates that solving practical engineering problems requires an interdisciplinary approach. A recommended introductory book on thermal systems engineering, [VT-2], covers the basics of thermodynamics, fluid mechanics, and heat transfer in an integral way.

Thus far, the remarks refer to thermal process engineering, i. e., processes without chemical reactions. A well-known German-language book on this subject is [VT-1]. There are also processes with chemical reactions in plastics processing, e. g., combustion or polymerization processes. In that case, we are talking about chemical process engineering; see, e. g., [VT-3].

Many chemical process engineering textbooks deal with reaction kinetics rather than energy rate balances relevant in energy technology. To limit the scope of this book, chemical reactions are covered only marginally in Chapter 3, Section 3.5.

The following chapters of Part 1 provide introductory explanations, key definitions, and basic principles of thermodynamics, fluid mechanics, heat transfer, and behavior of plastic materials. Extended fundamentals for practical purposes are covered in the chapters of Part 2. *End-of-chapter examples*, called basic examples, illustrate the application of basic principles of Parts 1 and 2. The *practical examples* of Part 3 intend to illustrate the interdisciplinary approach in solving problems of some fundamental processes of Figure 1.1. They all have been worked out jointly with industrial companies, machine manufacturers, and manufacturers of products made of plastics. To finish this introduction, we address three relevant issues:

- System analysis
- Kinds of systems
- Methodology for solving engineering problems

## 1.4.2 System Analysis

The critical step in any technical analysis is the precise description of what is to be analyzed, i. e., the proper definition of the system.

To illustrate the procedure, we will deal with a simple and illustrative example from mechanics. When examining the static and dynamic behavior of mechanical components (stress and strain levels, motion, etc.), the first step is always to create the so-called free body diagram of the element to be analyzed. Mechanics

The body is completely isolated from its surroundings. In mechanics, the term “free body diagram” is used for the *isolated body*, the system under consideration. Free body diagram

At the boundaries with the surroundings, *all* acting forces and moments are introduced. Then,

- the conditions of equilibrium → static cases
- Newton's laws of motion → dynamic cases

are formulated. We illustrate the methodology with the simple example of a rotary crane; Figure 1.4. The object of study shall be the crane's boom. We are interested in all forces acting under stationary conditions. It is of utmost importance that *all forces* and *moments*, known and unknown, are entered in the free body diagram, the isolated boom (in blue in Figure 1.4). They represent the *mechanical interaction* between boom and surroundings.

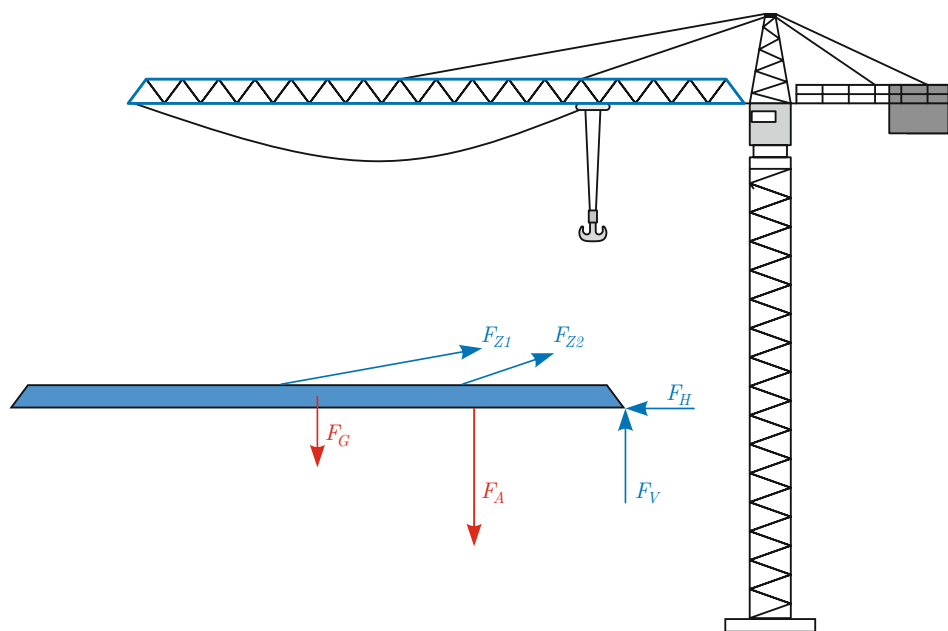

**Figure 1.4** Rotary crane: free body diagram of the component to be analyzed, the boom

In reality, the weight  $F_G$  is a distributed load (track load); for simplifying reasons, we introduce it as a single load (point load).  $F_A$  represents the horizontally sliding towing load. Both forces  $F_{Z1}$  and  $F_{Z2}$  describe the interaction with the tensile rods attached to the top of the crane tower. The effect of the joint on the right-hand side is specified by the horizontal and vertical bearing reactions,  $F_H$  and  $F_V$ . The bearing moment is of minor importance; therefore, we neglect it here.

Taking account of the weight of the rope cables depends on the objectives and the accuracy requirements of the analysis. A possible simplification could be to add the weight of the left-hand part of the hanging rope to the boom's weight and the weight of the right-hand portion to the towing load.



*Known forces* are the weight  $F_G$  – including the weight of the hanging rope – and the amount and the position of the sliding towing load  $F_A$ . The remaining four forces,  $F_{Z1}$ ,  $F_{Z2}$ ,  $F_H$ , and  $F_V$ , are *unknown*. For solving this two-dimensional problem, *three equilibrium conditions* can be formulated, *one* moment relation and *two* force relations – one in the horizontal and one in the vertical direction. Therefore, the problem is onefold statically indeterminate, i. e., we need an additional relationship, which can be obtained by considering the deformation conditions of the two tensile rods. If the boom is assumed to be rigid, the elongations of the tensile rods are in a fixed ratio given by the geometry. This ratio also applies to the ratio of the forces  $F_{Z1}/F_{Z2}$ , assuming linear-elastic deformation (Hooke’s law). This deformation condition gives an additional equation. All external loads acting on the boom are determinable. With known load conditions, stresses and deformations (deflections, elastic curve) can be determined. Of primary interest are locations of maximum stress and deflection.

In thermal systems engineering, with disciplines thermodynamics, fluid mechanics, and heat and mass transfer (Figure 1.3), the terms “*system*” and “*control volume*” are used instead of the term “free body diagram” used in mechanics. However, their role is the same in both cases, namely, the precise definition of the subject of the analysis. We say without exaggeration:



The system concept plays an equally important role in energy technology as the function concept in mathematics.

As shown with the simple mechanical example, the initial step in any engineering analysis is to precisely define what is to be analyzed, the *system definition*. The system is separated from the surroundings by the *system boundary*. Everything inside the system boundary belongs to the system; everything outside belongs to the surroundings.

Just as all forces and moments are entered in the free body diagram, all relevant *interactions between the system and the surroundings* are formulated at the system boundary and entered into the system sketch. These interactions are more diverse than in mechanics; for example, they include mass flows, heat flows, mechanical and electric power which may cross the system boundary at different locations. The analog to formulating equilibrium conditions or Newton’s laws of motion in mechanics is the formulation of the *rate balances*, primarily for the conservation quantities mass, momentum, angular momentum, and energy.



Fundamental steps when formulating rate balances for energy, mass, etc. are:

- Proper definition of the system
- Precise definition of the system boundary: What belongs to the system under consideration? What belongs to the surroundings?
- Complete description of the interaction between system and surroundings, i. e., formulation of all mass and energy flows crossing the system boundary

The system can be complex like an entire injection molding machine (Figure 1.5) or simple like a heat exchanger. It can also be a differential volume element when dealing with numerical methods for determining flow or temperature fields.

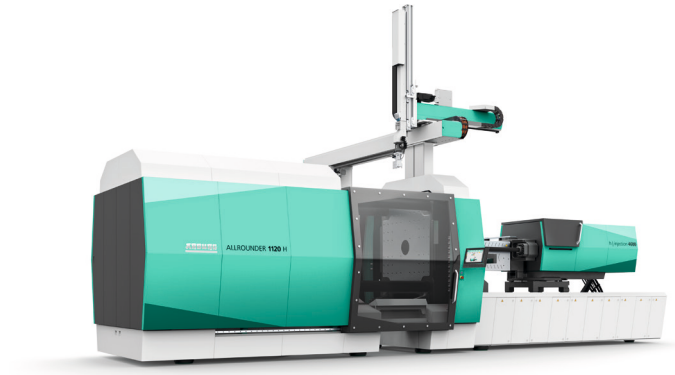

**Figure 1.5** Injection molding machine (image: Arburg GmbH + Co. KG)

**System** The system is a mental aid for problem analysis. It is a physical structure separated from the surroundings by an imaginary *closed surface* – the system boundary – completely enclosing the system.

**Control volume KV** When mass crosses the system boundary, the term “control volume” (*Kontrollvolumen* in German, abbreviated KV) is preferred for the region enclosed by the system boundary. The system boundary can be fixed or movable.

The appropriate choice of the control volume and system boundary, respectively, will depend on the type of problem to be solved. If the focus is on the energy budget of the entire injection molding machine, the system boundary is set around it. If the main interest is in the screw (granulate in, plastic melt out, heating, and driving power), an appropriate choice of the system boundary enclosing the screw would be along the inner surface of the barrel.

The system boundary should be placed so that the surroundings’ interactions can be described as precisely as possible. The art of selecting an appropriate and problem-oriented system boundary is a matter of experience.

An undeniable advantage of the system approach is that, at least for steady-state conditions, one does not have to worry about the details of complex processes within the system boundary. If it is possible to describe what happens at the system boundary with some degree of reliability, i.e., which mass and energy flow across the system boundary, the balance equations provide access to quantities that cannot accurately be measured or computed with reasonable effort.

### 1.4.3 Kinds of Systems

Depending on the problem to be solved, different system kinds are common in energy technology. The most important ones are *open*, *closed*, and *adiabatic* systems.

A system is open when energy and mass flows cross the system boundary. Keep in mind that mass flows, besides transporting mass, also transport energy. Section 3.3 deals with the first law of thermodynamics for open systems, where the property *enthalpy* will be defined. The transfer of thermal energy associated with a mass flow is called *convective thermal energy transfer*. Most systems in practice are open systems, for example, the tool of an injection molding machine whose temperature is controlled by oil or water flows. Open system

A system is closed if its boundary is *impermeable to mass*, i. e., the system's mass remains constant during the process under consideration. However, energy may cross the system boundary as heat and work. Example of a closed system: air inside a piston-cylinder assembly (displacement volume) of a piston engine with closed valves and dense piston rings. Energy transfer by work happens by moving the piston during the compression cycle. Energy transfer by heat takes place across the cylinder walls. Closed system

A system is adiabatic if its entire system boundary is *impermeable to heat*. Energy transfer may take place by work and/or mass flow only. In other words, adiabatic systems may be open or closed without heat transfer across its system boundary. The system boundary of a nonadiabatic system can be partially adiabatic. Adiabatic systems and adiabatic system boundaries are idealizations. Adiabatic system

### 1.4.4 Methodology for Solving Thermal Systems Problems

We strongly recommend adopting a proven systematic approach for solving thermal systems engineering problems. The methodology described here is used in English-language textbooks (e. g., standard textbooks by publishing companies such as John Wiley & Sons and McGraw-Hill, in particular, the excellent books [TH-3, 4, 5], [FM-2], [WU-3], and [VT-2]), but also increasingly in the German-speaking area, e. g., [WU-4, 5]. We call it *a six-point solution methodology*. Of course, it may be supplemented by additional sections or points without changing the essence of the methodology.

#### 1. Known (Given Data)

What do we know about the problem? What quantities are given or specified? Trying to answer these questions, studying the problem, and reflecting on the occurring processes are an integral part of the problem analysis.

## 2. Find

What does one want to know about the problem? What is to be determined? Jointly with step 1, consider what properties are to be determined, what transfer processes take place, and what relationships are involved. Points 1 and 2 should provide a comprehensive definition of the problem.

## 3. System and Schematic Diagram

Select the system appropriate to the problem. Set the system boundary so that the interaction with the surroundings can be expressed reasonably. Think about where one wants to determine quantities obtainable via the balance equations. Clear identification of the *interaction with the surroundings* is a relevant issue of this step. Consider what change the system undergoes: Is the process stationary or subject to changes in time? We strongly recommend sketching the system (→ schematic diagram) and entering *all* mass and energy flows at the locations where they cross the system boundary. All given properties should be listed as well.

**Example B 1.1** (Section 1.5) illustrates the interaction of a simple system with the surroundings for two different system boundaries.

## 4. Simplifying Assumptions

In general, technical systems and their interaction with the surroundings are complex, and their modeling needs to be simplified. Examples: one-dimensional flow, uniform pressure distribution, adiabatic walls, neglecting heat flows due to radiation, etc. It is advisable to list *all* simplifying assumptions and idealizations made. With this step, develop a suitable engineering model.

## 5. Analysis

In this step, equations are formulated, i. e., the balance equations for mass, energy, momentum, and, if necessary, angular momentum and other fundamental laws. We strongly recommend

- performing the analysis algebraically before introducing numbers,
- substituting numerical data after establishing functional relationships. Only in this way does the influence of the individual parameters become transparent,
- checking relationships and data for dimensional homogeneity,
- subjecting intermediate and final results to a plausibility check: Are the magnitudes of the numerical data reasonable?

In summary, the essential analysis steps are:

- Select an appropriate *coordinate system*.

- Define *boundary conditions*, and in the case of transient processes, define *initial conditions*.
- Specify *all interactions* of the system with the surroundings in conjunction with the boundary conditions.
- Depending on the problem to be solved, different laws are required, e.g., Fourier's law of heat conduction, material laws specifying the relationship between stress and strain for solid materials, describing viscosity for fluids, etc.
- Formulate *balance equations* for mass and energy (also for momentum and angular momentum if required) using the selected coordinate system.
- Solve equations or system of equations for quantities to be determined (flow field, temperature field, energy flows, etc.) and – if appropriate – graphically represent them.
- Take *material data* from relevant databases. For details, see Chapter 2. Because of plastics' enormous diversity and complexity, getting consistent data for solids and melts is still a real challenge.

## 6. Discussion

Following the analysis, the results obtained need to be judged in this step. In particular, one should examine to what extent the simplifying assumptions are appropriate and whether they need to be adapted. Is the choice of the system, including its boundary, reasonable? For complex problems, a first analysis using simplifying assumptions provides a “feeling for the order of magnitude” of the parameters involved, thus making it possible to specify more accurate assumptions for a second or even a third analysis step. This so-called *successive iteration procedure* is typical for engineering problem-solving in practice. In short, the methodology is:

- Perform a comprehensive problem assessment (steps 1 to 4) first.
- After that, perform the analysis, formulate and solve equations, and evaluate the results (steps 5 and 6). If necessary, add further iteration steps.

The sample solutions of all examples, the *basic examples* following each chapter of Parts 1 and 2 as well as the *practical examples* of Part 3, are treated using this methodology. It represents a way to model reality mathematically. This type of modeling is called *process simulation*, performed analytically or numerically.

In general, the analytical method requires simplifying assumptions. However, it does provide the essential relationships in the correct order of magnitude with comparatively little effort. Thus, if necessary, i.e., when higher accuracy results are required, the analytical method represents the starting point for more detailed investigations, like experiments or numerical simulations using advanced simulation tools.

Analytical method

Numerical method Numerical methods (finite difference method, FDM, or finite element method, FEM) are more complex; on the other hand, they allow a more realistic system modeling. Both methods, analytical and numerical, have their justification and are in use in plastics technology today.

In this introductory textbook, we limit ourselves to the analytical method. The analytical solutions – that is, their numerical results – of all examples are obtained using the software package Maple™.

## ■ 1.5 Example B 1.1: Interaction with the Surroundings for System Boundaries A and B of System “Extruder”

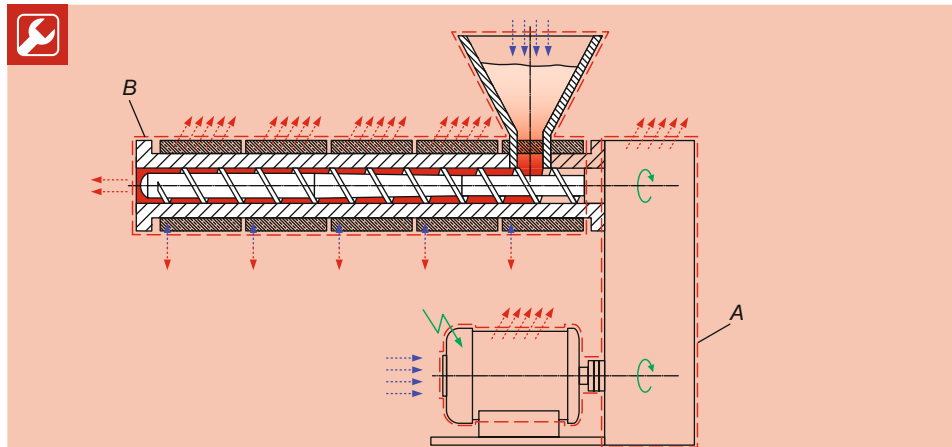

**Figure 1.6** System “extruder” with system boundaries A and B [KA-1]

**System boundary A “drive system” includes an electric drive motor, closed belt drive, and gear**

- Mass flows (note that the system boundary is placed on the surface of the elements): cooling airflow for cooling the drive motor; air enters with ambient air temperature and leaves system A at elevated temperature, thus transferring thermal energy to the surroundings
- Energy flows: electric power to drive motor → in, mechanical drive power to extruder screw → out
- Heat flows: heat transfer motor/belt/gear casing → surroundings due to free convection and radiation
- Convective thermal energy transfer by the motor cooling air, as mentioned above

### System boundary B includes funnel, hopper, and extruder

- Mass flows: granulate supply, extrudate at the outlet, heating and cooling fluid mass flow for temperature control
- Energy flows: mechanical power to extruder shaft, heating and cooling power (barrel), heat transfer barrel → surroundings due to free convection and radiation
- Convective thermal energy transfer by the plastic (granulate in, extrudate out)

Note that in both systems, convective energy transfers take place associated with mass flows.

## References Chapter 1

- [FM-1] Truckenbrodt, E. A.: *Fluidmechanik, Band 2: Elementare Strömungsvorgänge dichte­veränderlicher Fluide sowie Potential- und Grenzschichtströmungen (Klassiker der Technik)*, Springer, 2008
- [FM-2] Fox, R. W., McDonald, A. T., Pritchard, P. J.: *Introduction to Fluid Mechanics*, 8<sup>th</sup> Ed., SI version, John Wiley & Sons, 2011
- [KA-1] Kaiser, W.: *Kunststoffchemie für Ingenieure, Von der Synthese bis zur Anwendung*, 5<sup>th</sup> Ed., Hanser, Munich, 2021
- [KV-1] Stitz, S., Keller, W.: *Spritzgießtechnik, Verarbeitung – Maschine – Peripherie*, 2<sup>nd</sup> Ed., Hanser, Munich · Vienna, 2004
- [KV-2] Rauwendaal, Ch.: *Polymer Extrusion*, 2<sup>nd</sup> reprinted Ed., Hanser, Munich · Vienna · New York, 1990, and 5<sup>th</sup> Ed., 2014
- [KV-8] Agassant, J.-F., et al.: *Polymer Processing: Principles and Modeling*, 2<sup>nd</sup> Ed., Hanser, Munich, 2017
- [KV-9] Osswald, T. A.: *Understanding Polymer Processing: Processes and Governing Equations*, Hanser, Munich, 2017
- [TH-1] Baehr, H. D., Kabelac, S.: *Thermodynamik, Grundlagen und technische Anwendungen*, 16<sup>th</sup> Ed., Springer, 2016 (and earlier editions)
- [TH-2] Cerbe, G., Wilhelms, G.: *Technische Thermodynamik, Theoretische Grundlagen und praktische Anwendungen*, 17<sup>th</sup> Ed., Hanser, Munich, 2013
- [TH-3] Cengel, Y. A., et al.: *Thermodynamics, An Engineering Approach*, 9<sup>th</sup> Ed., SI version, McGraw-Hill Education, 2019
- [TH-4] Moran, M. J., Shapiro, H. N., Munson, B. R., DeWitt, D. P.: *Introduction to Thermal Systems Engineering, Thermodynamics, Fluid Mechanics and Heat Transfer*, Thermo: Ch. 1-10, international edition, John Wiley & Sons, 2003
- [TH-5] Moran, M. J., et al.: *Moran's Principles of Engineering Thermodynamics*, 9<sup>th</sup> Ed., SI version, John Wiley & Sons, 2017
- [VT-1] Grassmann, P., Widmer, F., Sinn, H.: *Einführung in die Verfahrenstechnik*, 3<sup>rd</sup> Ed., Walter de Gruyter, Berlin · New York, 1997
- [VT-2] Moran, M. J., Shapiro, H. N., Munson, B. R., DeWitt, D. P.: *Introduction to Thermal Systems Engineering; Thermodynamics, Fluid Mechanics, and Heat Transfer*, international edition, John Wiley & Sons, 2003
- [VT-3] Brandrup, J., Immergut, E. H., Grulke, E. A., Abe, A., Bloch, D. R. (Editors): *Polymer Handbook*, 4<sup>th</sup> Ed., John Wiley & Sons, 2003
- [WK-1] Menges, G., Haberstroh, E., Michaeli, W., Schmachtenberg, E.: *Menges Werkstoffkunde Kunststoffe*, 6<sup>th</sup> Ed., Hanser, Munich, 2011

- [WU-1] Baehr, H.D., Stephan, K.: *Wärme- und Stoffübertragung*, 9<sup>th</sup> Ed., Springer, 2016
- [WU-2] Bejan, A.: *Heat Transfer*, John Wiley & Sons, 1993
- [WU-3] Incropera, F.P., DeWitt, D.P., Bergman, T.L., Lavine, A.S.: *Foundations of Heat Transfer*, 6<sup>th</sup> Ed., international student version, John Wiley & Sons, 2013
- [WU-4] Marek, R., Nitschke, K.: *Praxis der Wärmeübertragung, Grundlagen - Anwendungen - Übungsaufgaben*, 4<sup>th</sup> Ed., Fachbuchverlag Leipzig im Carl Hanser Verlag, Munich, 2015
- [WU-5] Von Böckh, P., Wetzel, T.: *Wärmeübertragung, Grundlagen und Praxis*, 6<sup>th</sup> Ed., Springer, 2015



# 2

## Material Behavior of Plastics

Compared to other classes of materials, plastics are characterized above all by a unique variety of properties (such as crystal clear or opaque, tough or soft, nonconductive or conductive) that they offer for a wide range of applications. The Latin expression “*mixtura miraculosa*” would therefore be much more appropriate than the word plastic, which is derived from the Greek term *plastikos*: to form/shape. But all joking aside, almost all plastics exist usually as **complex mixtures!**

For a better understanding of plastics, the following “word equation” – also called the main theorem of plastics technology – has a key function in the field of plastics engineering, especially in solving upcoming problems:



*Polymer raw material(s) + Additive(s) → Plastic*

Main theorem of  
plastics technology

The arrow symbol indicates the process steps of preparation/processing.

In addition, the transparency of this simple statement is complicated by the fact that in everyday life the same designations are used for the polymer raw material(s) (“polymer”) as well as for the plastic – for instance, polyethylene terephthalate (PET) in use for bottles.

Last but not least, it should be remembered that this mixture of substances has been prepared with great care. So even the smallest changes (of any kind) in the mixing ratio of the two components must be expected to have profound consequences for the plastic in question.

Finally, among the many topics available on the material behavior of plastics, a strict selection was made on the premise that the following text would at least indirectly maintain the reference to energy.

### The Most Important Facts in Brief

Anyone wishing to understand plastics, their properties, processing, and applications right through to recycling from the ground up must be familiar with their chemistry. Right at the beginning of this chapter, therefore, the aim is to convey as

simply as possible the basic chemistry required for the content of this book, Section 2.1. Armed with this prior knowledge, the focus shifts from chemistry to physics including energetic behavior, Section 2.2.

The focus is now on the behavior of the various types of plastics in the solid and viscous or “molten” states and their dependence on temperature and time. In this context, *thermodynamic properties* become very important not only for this book, but mainly because of their central influence in dealing with plastics, Section 2.3.

Furthermore, the sustainable development goals (SDGs) for the future of plastics cannot be achieved without adequately considering the influence of energy in the form of heat and light – often combined with oxygen – on components or semi-finished products. This is illustrated in a separate section using the example of the ageing of plastics, Section 2.4.

At the same time, it should be recalled once again that in the case of plastics, both the polymer raw material(s) used and the finished blend with additives are almost invariably given the same designation.

This chapter is rounded off with the topic of strain energy and elasticity of solid plastics; see Section 2.5.

## ■ 2.1 Chemical Basics

**Macromolecule** A broader understanding of the material behavior of plastics requires basic information about the different structure of polymers compared to other materials, for example, metals. In the structure of metals, atoms are considered as their smallest building blocks, which are arranged in atomic lattices. If we compare water, H<sub>2</sub>O, or carbon dioxide, CO<sub>2</sub>, with a polymer at this point, the smallest building block common to all is the molecule. But polymers, in contrast, have molecules with at least 1000 atoms being involved, as the lowest limit. The term *macromolecule* is used to take this characteristic into account. However, not only the macromolecule alone but also the *chemical elements* involved in its structure are of fundamental importance for the material behavior of the plastic in question. In addition to the chemical element carbon, these are, above all, hydrogen, oxygen, and nitrogen, all of which belong to the lightweights due to their atomic structure and together explain the *low density of polymers*; see Section 2.2.1.

### **Chemical Synthesis**

As far as the chemical synthesis of macromolecules is concerned, there are many different possibilities; see Figure 2.1.

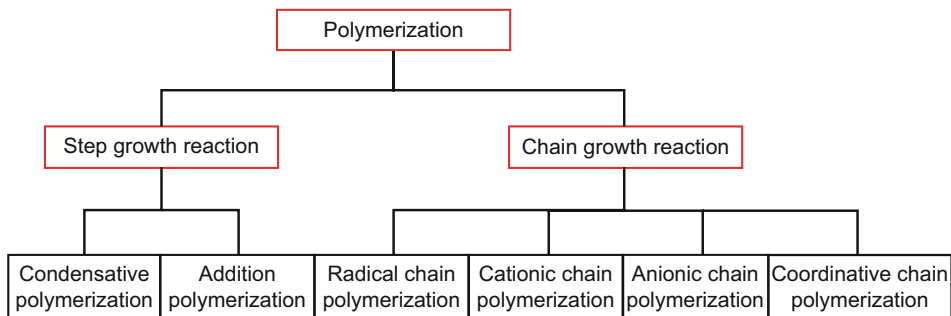

**Figure 2.1** Classification of polyreactions, from [KA-1]

One of them is called *chain growth reaction*, which is explained in Figure 2.2 using the simple example of the generation of the macromolecule polyethylene. The starting material is the *monomer ethylene* (ethene). By “splitting” its double bond, many monomers can form a chain (macromolecule) together.

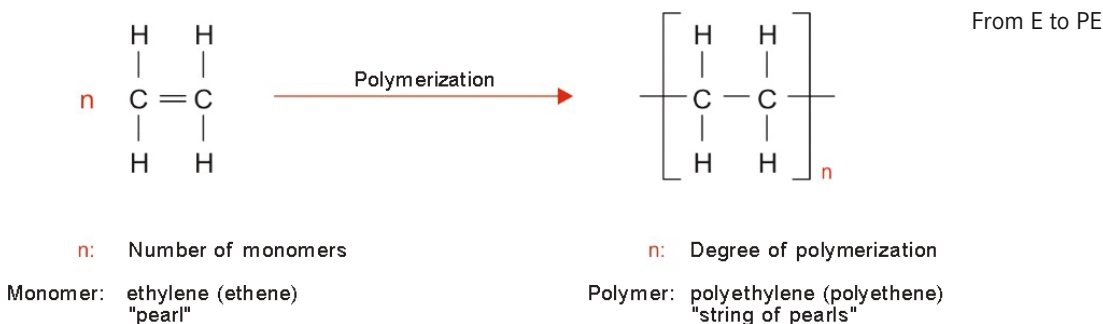

**Figure 2.2** Simplified representation of a chain polymerization from monomer to polymer using the example of polyethylene

A *pure polymer* (polymer raw material) thus consists, in the simplest case, of a multitude of chemically identical macromolecules, whereby, depending on the type of plastic, special spatial arrangements are formed, for instance, linear chains or in helix form.

### 2.1.1 Polymer Raw Material(s)

First of all, the influence of a polymer raw material (“polymer”) is to be discussed using the example of *polypropylene, PP*. Propylene, P (monomer), can be converted into a polymer with different properties during polymerization to polypropylene (polymer raw material) by different manufacturing conditions such as pressure

Influence of the molar mass

and temperature, but especially by highly specific catalysts. Thus, using the example of PP, the same polymer raw material is obtained with variable molar masses or molar mass distribution; see Figure 2.3.

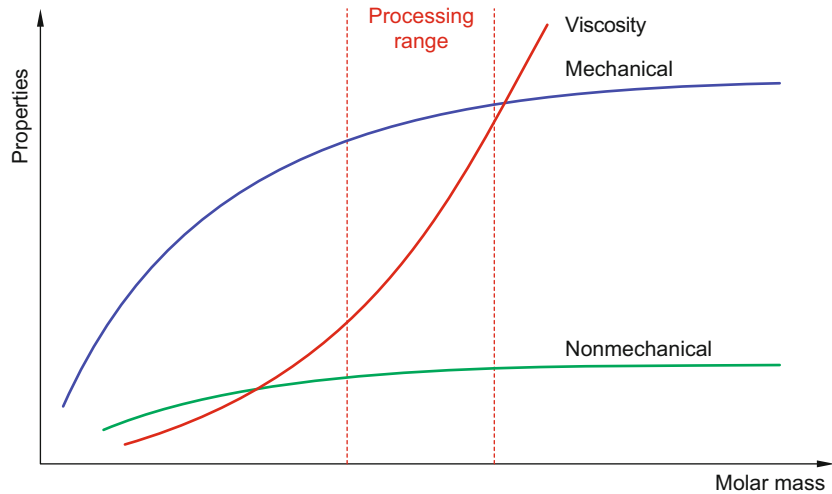

**Figure 2.3** Influence of the average molar mass on physical properties in schematic representation, from [KA-1]

**Bimodal distribution** If the specific advantages of both low and very high molar masses are to be combined, the production of a plastic with *bimodal distribution* of the polymer molar mass is an option; see Figure 2.4.

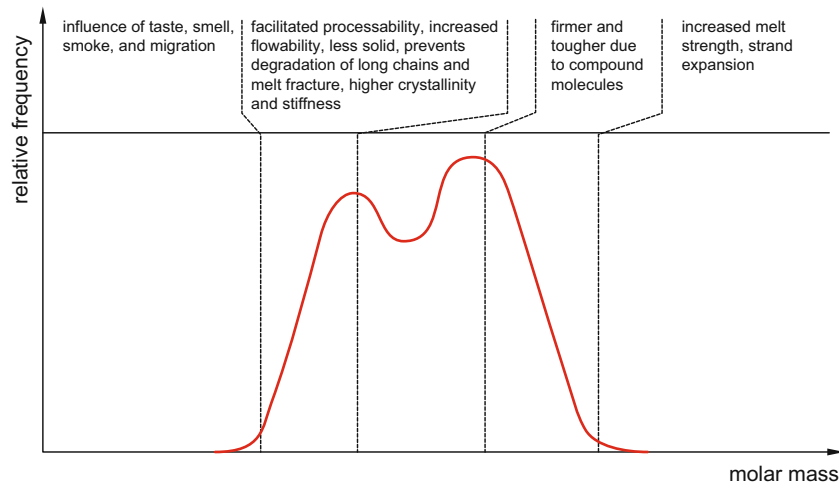

**Figure 2.4** Schematic of a bimodal distribution curve, from [KA-1]

Further possibilities to obtain “tailor-made polymers” for practical use are offered by the numerous variants of *chemical modification of polymers*. This is achieved, in the case of PP, for example, through the use of additional monomers, e. g., ethylene. Under the generic term “*PP copolymers*,” they find a wide range of applications; see Figure 2.5.

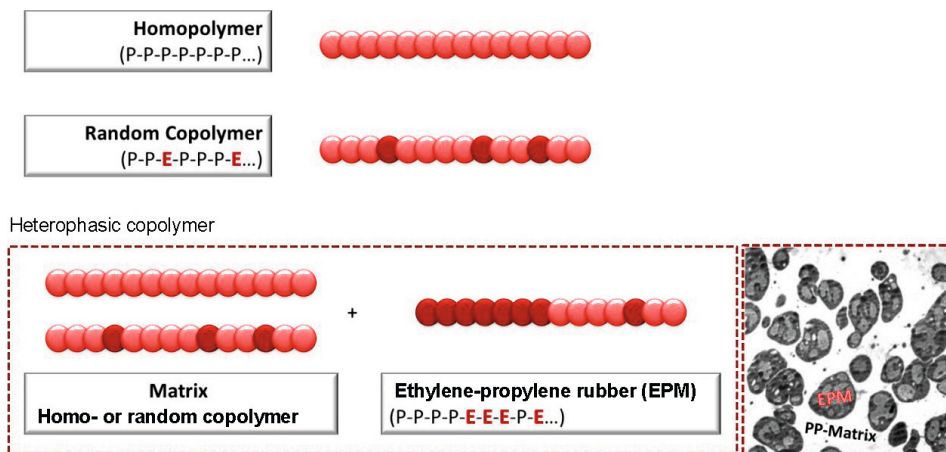

**Figure 2.5** Schematic structure of propylene copolymers, from [KA-1]

Last but not least, further chemical modifications can be made to the finished polymer raw material. One example is the subsequent chemical cross-linking of thermoplastics.

It should be noted at this point that the possibilities of “tailoring” a polymer raw material that have been described so far and those that follow do not claim to be exhaustive, but – as already mentioned – are to be understood only as *typical examples*.

It is also deliberately intended in Section 2.1 to largely dispense with chemical and physical formulae in the *further description of the material behavior* and instead to give priority to the qualitative approach with words and pictures.

### 2.1.2 Additive(s)

Similarly, the properties of a plastic for its intended use in practice can be permanently changed by a selective choice of additives. In everyday plastic applications, these additional possibilities of *physical modification* are almost always exploited to produce high-quality components or semifinished products (pipes, sheets, profiles, etc.), mostly in combination with the already-mentioned chemical variants to optimize the polymer raw material.

Physical modification

Using several examples – initially as undesirable effects – physical modification will also be explained in more detail. PP, for example, is *hydrophobic* when used as a plastic due to its chemical structure. The situation is completely different with PP reinforced with glass fiber. The physical phenomenon of the wettability of glass fibers by water film ( $H_2O$ ) therefore requires *controlled pre-drying* even before processing in the melting process; see Chapter 8. Otherwise, the desired improvement in mechanical properties would lead to a fault in the component due to water vapor formed as a result, e.g., formation of streaks and bubbles. Polyethylene terephthalate (PET) behaves even more extremely in processing, for example, in the injection molding of preforms used to produce PET bottles. Even as an unreinforced polymer raw material, it is susceptible to *hydrolysis* in the presence of even the smallest traces of water, due to its polyester structure, and consequently requires *extreme pre-drying* before processing. In complete contrast, a polyamide, e.g., PA 66, only acquires its toughness through the absorption of water as an external plasticizer.

Consequential color change Moreover, for example, a color change in the same plastic, e.g., from green to red, can lead to unforeseen consequences such as *shrinkage behavior*.

The modification of the polymer raw materials with additives takes place, depending on the requirements for the plastic part in question, either already at the polymer raw material manufacturer (producer) and/or during compounding or at the processor. Table 2.1 summarizes the individual requirements for additives. At the same time, this list provides a simple explanation for the huge variety of different plastic products that are encountered in everyday life.

Recycling of plastics On the flip side, however, this forces all parties involved to pay due attention to plastics recycling from as early as the development stage of new products in the future.

Taking into account new scientific findings and improved technologies in the field of plastics technology, further growth in the plastics industry can therefore be expected worldwide.

**Table 2.1** Thematic Overview: Additives for Plastics (Selection), from [KA-1]

Reaction substances	Processing-enhancing additives	Strength-increasing additives	Stiffness-increasing additives	Stiffness-decreasing additives
<ul style="list-style-type: none"> <li>▪ Hardeners (cross-linkers)</li> <li>▪ Photo-initiators</li> <li>▪ Catalysts</li> <li>▪ Accelerators</li> <li>▪ Propellants (for foams)</li> <li>▪ Degradation-causing additives</li> </ul>	<ul style="list-style-type: none"> <li>▪ Stabilizers (against heat)</li> <li>▪ Antioxidants</li> <li>▪ Lubricants</li> <li>▪ Bonding agents for filling materials, fibers, etc.</li> <li>▪ Nucleating agents</li> <li>▪ Antistatic agents</li> <li>▪ Release agents</li> </ul>	<ul style="list-style-type: none"> <li>▪ Reinforcements like fibers, fabrics, mats</li> <li>▪ Fillers with reinforcer effect (e.g., carbon black, silica for elastomers)</li> <li>▪ Resin carriers for thermosets (e.g., wood flour, cellulose)</li> </ul>	<ul style="list-style-type: none"> <li>▪ Reinforcements like fibers, fabrics, mats</li> <li>▪ Fillers without reinforcer effect (e.g., silicon flour, rock flour)</li> </ul>	<ul style="list-style-type: none"> <li>▪ Plasticizers</li> <li>▪ Rubber-like polymers, mixed into the softening plastic (so-called polyblends, e.g., nitrile rubber in PVC or chlorinated PE in PVC)</li> </ul>
Antimicrobial additives	Lifetime-prolonging additives	Coloring additives	Properties-modifying additives	Cheapening additives
Biostabilizers against biological attack (e.g., fungistatics against fungus)	Stabilizers against light, oxidation, heat (also called anti-ageing agents)	<ul style="list-style-type: none"> <li>▪ Pigments</li> <li>▪ Dyes</li> <li>▪ Brightening agents (e.g., fluorescent brighteners for PVC)</li> </ul>	<ul style="list-style-type: none"> <li>▪ Flame retardants</li> <li>▪ Heat-conduction-improving additives (e.g., metal powder)</li> <li>▪ Antistatics</li> </ul>	Cheap fillers (e.g., slate flour, chalk, etc., so-called stretching agents)

For a more in-depth understanding of the chemical and physical influences discussed so far – especially with regard to the properties of a plastic – the reader is referred to the relevant technical literature.

### 2.1.3 Classification of Plastics

Plastics can be classified according to a wide variety of criteria, e.g., according to their production, recyclability, areas of application, etc. The *main criterion*, however, remains the following: their different behavior at *elevated temperature*. Thus, two types can be defined initially:

- Non-cross-linked plastics
- Cross-linked plastics

Temperature as a guideline

# Index

## A

absolute (Kelvin) temperature 97  
absorptivity 228  
activation energy 71  
activation energy (enthalpy) 131  
additive manufacturing 43  
additives 23, 25, 56, 70  
adiabatic saturation temperature 353  
adiabatic wall 389  
ageing 70  
– external causes 70  
– internal causes 70  
ageing process 70  
air-drying of solids 365  
amorphous 32, 33, 40, 50, 54, 65, 78  
anergy 99  
anisotropy 60  
Arrhenius equation 385  
aspiration psychrometer 354  
availability = exergy of heat 98  
axial annular flow 400

## B

Bernoulli equation 121  
– generalized 125, 184, 413  
bimodal distribution 22  
Bingham fluid 162  
biotechnology 438  
Biot number 291, 301  
blackbody 226

bladder accumulator 485  
bond energy 26, 130  
bonds  
– chemical 26  
– covalent 26  
– hydrogen 30  
– main valence 26, 49  
– mechanical 31  
– secondary valence 28, 34, 48, 49  
break point 356  
Brinkman number 390  
Brownian motion 33  
Buckingham pi theorem 176  
bulk modulus 78, 491

## C

Carnot  
– efficiency 97  
– heat engine 96  
– refrigeration cycle 101  
Carreau model 384  
ceiling temperature 134  
Celsius temperature 97  
cement industry 445  
change of (thermodynamic) state  
– definition 111  
– nonequilibrium or nonstatic 112  
chemical process engineering 9  
chemical reaction 128  
– endergonic 134  
– endothermic 130  
– exergonic 134  
– exothermic 130  
– reversible work 135  
coding system 435  
coefficient of friction 481  
coefficient of performance COP 101, 137  
coefficient of thermal expansion 76  
– linear 59  
coefficient of volume expansion 68  
complementary error function 293  
compounding 71  
compressibility 68, 78, 491  
compressibility chart 103  
conduction 197  
conservation law 157  
constitutive equation 168, 173  
continuum model 155  
control volume 11, 12  
convection 197, 198  
– definition 206  
– forced 198, 209  
– free 198, 219  
cooling limit 353  
copolymer 23, 33, 35  
critical insulation radius 241  
Cross model 384  
crude oil 445  
cycle time 4



**D**

Dalton's law 339  
 Deborah number 166  
 depolymerization 437  
 deviatoric tensor 169  
 dew point 340  
 differential scanning calorimetry 51, 60  
 diffuse-gray surface 230  
 diffusion coefficient 358  
 dilatant behavior 161  
 dimensional analysis 174  
 dioxins 443  
 dipole-dipole forces 29  
 directional distribution 223  
 dispersion forces 29, 49  
 displacement work 110  
 dissipation 100  
 downcycling 436  
 drag flow 158, 171, 385, 388  
 dry-bulb temperature 354  
 drying  
 – definition 337  
 – mechanisms 338  
 – phase I 355  
 – phase II 356  
 drying rate 357  
 DSC 51, 60  
 duromers 37

**E**

elastomer recycling 437  
 elastomers 26, 27, 36, 39, 47, 64, 82, 83  
 elongation rate 163  
 emissive power 224  
 – spectral 224  
 – total 224  
 emissivity  
 – spectral 228  
 – total 228  
 energetic approach 61  
 energetic recovery 439

energetic recovery, controlled 441  
 energy  
 – gravitational, potential 104  
 – internal thermal 104  
 – kinetic 104  
 – total 104  
 energy balance 445  
 – closed system between states 1 and 2 105  
 energy balances  
 – in plastics technology 63  
 – in thermodynamics 63  
 energy efficiency 62, 428, 442  
 energy efficiency of waste-to-energy plants 444  
 energy rate balance 118  
 – closed system, time rate form 106  
 – control volume 120  
 entanglements 31  
 enthalpy  
 – definition 119  
 enthalpy of reaction (reaction enthalpy)  
 – definition 130  
 entrance length 183  
 – thermal 399  
 entropy  
 – definition 101, 113  
 entropy-elastic behavior 41, 82  
 equation of state  
 – caloric 102  
 – thermal 102  
 Eulerian description 167  
 example 15  
 – basic 9, 15  
 – practical 9, 15  
 exergy  
 – definition 99  
 exergy analysis 140, 456  
 extended surfaces (fins) 263  
 extensional flow 158  
 extrudate swell 164

**F**

Fick's law 358  
 fin effectiveness 268  
 fin efficiency 268  
 fin parameter 265  
 first law of thermodynamics 95  
 – closed system 105  
 – open system (control volume) 118  
 flow  
 – laminar 212  
 – turbulent 212  
 flow behavior 41, 43  
 flow work 119  
 fluid  
 – definition 155  
 fluid mechanics 8  
 Fourier number 289, 301  
 Fourier's equation of heat conduction 282  
 Fourier's law of heat conduction 199, 202, 282  
 free body diagram 9  
 free volume 27  
 frictional force 481  
 frictional power 479, 481  
 friction factor (Darcy) 175, 190  
 friction factor (Fanning) 176  
 friction pump 407  
 friction welding 479  
 friction work 124  
 Froude number 414  
 fuel cell 135

**G**

gas constant  
 – air and water 340  
 – individual 103  
 – universal 103  
 Gaussian error function 293  
 Gibbs free energy  
 – definition 132  
 glass temperature 33, 34

Graetz number 393  
 Grashof number 208, 220

## H

Hagen–Poiseuille equation 181, 186  
 – generalized 182  
 heat and mass transfer 8  
 heat conduction  
 – boundary condition 284  
 – contact problem 295  
 – contact temperature 295  
 – early regime 288, 289  
 – late regime 289  
 – periodic temperature variation 296  
 – semi-infinite body 292  
 – steady-state 199  
 – thermal penetration depth 298  
 – transient 281  
 – transition phase 289  
 heat conductivity 199  
 heat exchanger 204  
 heat flux 197  
 heating value 439  
 – higher (HHV) 130  
 – lower (LHV) 131  
 heat pump 136  
 heat transfer  
 – coefficient 198, 207  
 – definition 197  
 – rate 197  
 heat transfer coefficient  
 – total or overall 200, 203  
 Hooke's law 168  
 humidity ratio 341  
 hydraulic diameter 178  
 hydrophobic 24

## I

ideal gas equation of state 103  
 ideal gas equations of state 340

impinging jet 216  
 incompressibility 78  
 induction forces 30  
 interaction with the surroundings 11  
 irradiation 224  
 – spectral 225  
 – total 225  
 irreversibility 100, 111  
 isothermal wall 389  
 isotropy 60

## K

Kirchhoff's law 230

## L

Lagrangian description 167  
 landfill 443, 446  
 Laplace transformation 284  
 Lewis number 361  
 life cycle assessment (LCA) 440  
 littering 446  
 lubrication approximation 387  
 lumped-capacitance model 289

## M

Mach number 155  
 macromolecule 20, 26, 27, 34, 38, 53, 82  
 main theorem of plastics technology 19  
 manufacturing processes 4  
 mass rate balance 117  
 mass transfer coefficient 359  
 material behavior 19, 20, 74, 78, 80  
 material efficiency 62  
 mechanical recycling 434  
 melting range  
 – crystallite 34  
 melting temperature  
 – crystallite 34

method 15, 16  
 – analytical 15  
 – numerical 16  
 methodology 13  
 microplastics 440  
 modification 24  
 – chemical 23  
 – physical 23  
 moist air 339  
 – cooling 346  
 – definition 341  
 – specific enthalpy 343  
 – specific volume 342  
 – water and steam injection 347  
 moist solid  
 – definition 349  
 – moisture content 349  
 – specific enthalpy 349  
 molar mass 103  
 – air and water 340  
 Moody diagram 177

## N

Newtonian fluid 155, 161, 163  
 Newtonian fluids 41  
 Newton's law of cooling 198, 207  
 non-Newtonian fluid 156, 161, 163  
 normal stress 169  
 normal stress difference 170, 171  
 numerical procedures 405  
 Nusselt number 208

## O

Ohm's law 201  
 opaque material 229

## P

Péclet number 393  
 perpetuum mobile  
 – second kind 100  
 petroleum, added value 429

- petroleum consumption 427  
 phonons 54  
 Planck distribution 227  
 plastic waste 431  
 plastic waste, utilization 434  
 polyethylene 445  
 polymer 19, 20, 21, 26, 27, 34, 70, 84  
 polymer raw material 19, 21, 24  
 polytropic exponent 142  
 power law 383  
 Prandtl number 208  
 preform 24  
 pressure flow 158  
 pressure integral 124, 127  
 pressure loss coefficient 184, 190  
 principle of conservation of energy 105  
 principle of corresponding states 103  
 process  
   – definition 111  
   – quasi-equilibrium 108  
   – reversible 110  
 processing stages 5  
 property 101  
   – caloric 104  
   – extensive 104  
 psychrometric chart (Mollier) 344  
 p-v-T diagrams 42, 65, 69  
 p-v-T relation 102  
 pyrolysis 437
- Q**
- quality factor 98
- R**
- radiation 197  
   – blackbody 226  
   – diffuse directional distribution 223  
   – spectrum 223  
   – thermal 222  
 radiative exchange 231  
   – blackbody 236  
   – diffuse-gray surfaces 237  
 radiative exchange coefficient 239  
 radiative heat transfer coefficient 232  
 radiative resistance  
   – space or geometrical 236, 239  
   – surface 238  
 radiosity 224, 225, 230  
 rate of strain tensor 168, 172  
 raw material recycling 437  
 Rayleigh number 208, 220  
 reaction enthalpy (enthalpy of reaction)  
   – standard 130  
 real gas behavior 489  
 recycling 425  
 reflectivity 228  
 relative humidity 342  
 reptation 31  
 resource efficiency 62  
 Reynolds analogy 211  
 Reynolds number 6, 155, 175, 208  
 rheology 156
- S**
- Sankey diagrams 64  
 Schmidt number 360  
 sealing point 69  
 second law of thermodynamics 96  
 semicrystalline 32, 34, 50, 53, 65  
 service life 432  
 shear rate 41, 46, 160  
 shear stress 160, 169  
 shear-thinning behavior 162  
 Sherwood number 360  
 sign convention 105, 120  
 similarity 174, 177  
 similarity theory 407  
 softening temperature 33  
 solvolysis 438  
 sorption isotherm 352  
 specific enthalpy 51  
 specific heat capacity 50, 51  
   – at constant pressure 122  
   – at constant volume 105  
   – for liquids 123  
 specific heat ratio 142  
 specific volume 27, 32  
 spectral distribution 223  
 stabilizers 72  
 Stanton number 208  
   – interpretation 210  
 Stefan-Boltzmann constant 226  
 Stefan-Boltzmann law 226  
 strain rate tensor 128  
 strain tensor 168  
 stresses  
   – compressive 76  
 stress tensor 74, 128, 168, 169  
 stress vector 169  
 stretching 55, 83  
 structural viscosity 41  
 sublimation enthalpy 344  
 surface-to-content problem 291  
 sustainable development goals (SDGs) 429  
 swelling 41  
 system 13  
   – adiabatic 13  
   – closed 13  
   – open 13  
   – open (control volume) 116  
 system analysis 9  
 system boundary 11  
 system concept 11  
 system definition 11
- T**
- T-ds relation  
   – first 115  
   – second 123  
 techno-climate 40, 70  
 tensorial description 156, 167  
 thermal ageing behavior 71

- thermal analysis 51, 60
  - thermal characteristics 55
  - thermal conductivity 6, 54, 57
  - thermal diffusivity 57, 283, 393
    - effective 315
  - thermal effusivity 294, 296, 482
  - thermal expansion coefficient
    - volumetric 220
  - thermal process engineering 9
  - thermal resistance 201, 202
    - contact 201
    - specific, conduction 201
    - specific, convection 201
  - thermodynamic measurement method 151
  - thermodynamics 8
  - thermomechanical behavior 32
  - thermoplastic elastomers 35
  - thermoplastic recycling 435, 437
  - thermoplastics 26, 31, 33, 34, 37, 40, 61, 65
  - thermoset recycling 437
  - thermosets 26, 27, 37, 39, 47, 64
  - third law of thermodynamics 102, 129
  - transmissivity 228
  - triple point 340
- U**
- useful energy 446
- V**
- vectorial description 167
  - view factor 233
    - definition 233
    - reciprocity relation 234
    - summation rule 234
  - viscoelasticity 7, 83
  - viscosity 6
    - elongational 158, 162
    - representative 405
    - shear 158, 160
    - temperature-dependent 186
    - transient 165
  - viscosity functions 43
- W**
- volume integral 109, 126
  - volume shrinkage 65
  - wall slip 395
  - waste and recycling hierarchy 431
  - waste heat 4
  - waste management 431, 433
  - waste-to-energy plant 441
  - Weissenberg effect 164
  - Weissenberg number 166
  - welding
    - infrared 64
    - laser-beam 64
  - wet-bulb temperature 354
  - Wien's displacement law 227
  - work
    - friction work 113
- Z**
- zeroth law of thermodynamics 95